

# PART E

## Battery packs and chargers

This part provides information on the battery packs and chargers available for Tait Orca 5000 portable radios.

The battery packs are not serviceable, and repair of chargers is limited to replacement of the spring contacts, the discharge tact switch and the DC jack.

---

### Contents

<b>Battery packs</b> .....	<b>E-3</b>
Battery shift life .....	E-3
Disposing of used nickel-cadmium batteries .....	E-4
<b>Battery chargers</b> .....	<b>E-5</b>
<b>Desktop fast charger</b> .....	<b>E-6</b>
Fast charger operation .....	E-6
Using the fast charger .....	E-9
Repairing the fast charger .....	E-10
<b>Desktop trickle charger</b> .....	<b>E-12</b>
Trickle charger operation .....	E-12
Using the trickle charger .....	E-13
Repairing the trickle charger .....	E-13
Troubleshooting .....	E-14
<b>Multi-charger</b> .....	<b>E-15</b>
Multi-charger operation .....	E-15
Repairing the multi-charger .....	E-15
Fuse replacement .....	E-16



# Battery packs

Six battery packs are available for Tait Orca 5000 portable radios. These battery packs are not serviceable, but their construction and expected life are described below.

The battery packs available are:

- TOPB100 NiCD battery pack;
- TOPB600 NiCD battery pack (slim, no belt clip);
- TOPB200 NiCD battery pack;
- TOPB400 NiMH battery pack;
- TOPB700 NiMH battery pack (slim, no belt clip); and
- TOPB500 NiMH battery pack.

The battery casing is constructed using a rugged resin material, and includes two pieces that are ultrasonically welded together.

## Battery shift life

Battery shift life is outlined in Table E-1. Battery shift life for other models and circumstances can be calculated from the typical drain rates on page E-4.

For intrinsically safe batteries, see page A-11.

## Preserving battery shift life

It is important that you follow the steps below

to preserve the shift life of the battery:

- Charge or change the battery as soon as the radio gives the 'Low Battery' warning.
- Short condition the battery weekly.
- Long condition the battery only for the following reasons: on first use of new battery, if performance is poor, and after more than two weeks of storage.
- Avoid leaving charged batteries in the charger for more than a day.
- Clean electrical contacts of the battery using a fibre glass pencil, or the graphite tip of a type 4H (#4) or harder pencil.
- Always store the battery detached from the radio when storing for more than a few days.
- Turn the radio off when it is unattended for long periods.
- Use only a Tait-recommended charger.
- Maintain an ambient temperature of between 5°C and 40°C during recharging. Optimum battery performance will be obtained between 15°C and 25°C.
- Do not allow the battery pack contacts to become short-circuited.

Table E-1: Typical battery shift life (in hours) based on a 5:5:90 duty cycle for a new conditioned battery pack\*.

Battery type	Radio type		
	Conventional - Medium Economy	Conventional - No Economy	Trunked
TOPB100/600 NiCD	8.5	7	6.5
TOPB400/700 NiMH	10.5	8.5	8
TOPB200 NiCD	11.5	9	8.5
TOPB500 NiMH	15	12	11

\* Users should aim to have one hour spare capacity at the end of their shift to allow for battery ageing.

## Extending battery shift life

Battery shift life can be extended by activating economy mode (conventional radios) or by using dynamic power control (trunked radios).

During economy mode, the radio cycles between the normal receive state and a standby state, in which some of the radio's circuitry is switched off or placed on standby mode. Dynamic power control optimises the radio's power use by reducing the transmit power in high signal strength areas.

Typical drain rates for a conventional UHF radio are:

- 1.5 A at high power transmit;
- 300 mA in receive at rated audio;
- 80 mA on standby (no audio);
- 55 mA with low economy cycling enabled;
- 45 mA with medium economy cycling enabled; and
- 40 mA with high economy cycling enabled.

Economy cycling in conventional radios is programmed in the **Power Save Features** screen of the *Tait Orca Portable Conventional Programming Application (TOPCPA)*. Dynamic power control in trunked radios is enabled in the **User Selectable Parameters** screen of the *Tait Orca Portable Trunked Programming Application (TOPTPA)*.

## Disposing of used nickel-cadmium batteries

NiCd batteries contain a small amount of the metal cadmium, which can produce potentially toxic waste if not disposed of properly. Contact your Tait dealer for recycling details.

# Battery chargers

**Note:** In order to charge TOPB700 NiMH batteries, the charger must have firmware version 2.07 or greater. TOPB500 NiMH batteries can be charged on chargers with firmware version 2.05 or greater.

Three battery chargers are available for Tait Orca portable radios:

- desktop fast charger;
- desktop trickle charger; and
- six-way multi-charger.

The fast charger charges, conditions and analyses the battery. The trickle charger only charges the battery, and does not have a conditioning button but is otherwise identical in appearance to the fast charger. The multi-charger is made up of six fast chargers, and charging instructions for the fast charger also apply to the multi-charger.

The trickle charger should not be used for NiMH battery packs as they can take up to 24 hours to charge fully and the overall lifetime of the battery may be reduced. NiMH battery packs should be charged using a fast charger.

For details on charging intrinsically safe batteries, see page A-11.

Repair of chargers is limited to replacement of the spring contacts, the discharge tact switch and the DC jack.

The repair information provided for the fast charger also applies to repair of the trickle charger and multi-charger.

A spares kit is available for Tait Orca chargers (TOPA-SP-202). The contents of the spares kit is shown in Table E-2, and the assembly of these parts is shown in Figure E-3.

Table E-2: Contents of the Tait Orca chargers spares kit (TOPA-SP-202)

IPN	Description	Quantity	For charger
240-02020-07	Skt DC jack	10	All
232-00010-28	Tact switch	10	Desktop fast charger Multi-charger
302-40054-01	Conditioning button	10	Desktop fast charger Multi-charger
262-00001-00	Charger light pipe	10	Desktop fast charger Multi-charger
312-01069-02	Charger top	10	All
312-01070-01	Charger base	10	All
365-01549-01	Charger logo label	10	All
365-01598-01	Charger labels	10	Desktop fast charger Multi-charger
365-01601-00			
365-01597-00	Charger labels	5	Desktop trickle charger
365-01601-02			
369-00010-11	Rubber charger foot	40	All
360-01059-00	Trickle charger blanking label	10	Desktop trickle charger
356-01079-00	Spring probe charger bias-ball	40	All

---

# Desktop fast charger

---

The Tait Orca desktop fast charger (Figure E-1) is an intelligent charger that can charge, condition and analyse both NiCd and NiMH batteries of varying capacities.

## Fast charger operation

A circuit diagram of the fast charger is shown in Figure E-2. The fast charger operates using constant current charging and multiple criteria for end-of-charge detection. When a battery is inserted, the charger detects the type of battery, checks to see if it is working correctly, and then charges the battery.

If the conditioning button is pressed after inserting the battery, the charger will discharge the battery before charging. If the conditioning button is held down while the battery is being inserted, the charger will enter a long condition cycle that will charge and discharge the battery a number of times and, on the last cycle, check its capacity before recharging.

Multiple protection methods are employed to ensure safe operation.

Figure E-1: Tait Orca fast charger

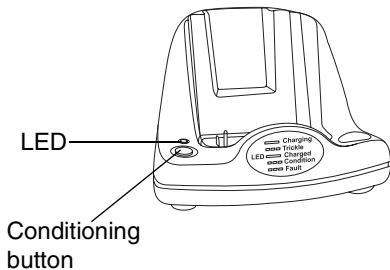

## Hardware operation

Power to the unit is provided from a 12 volt, 1 amp (nominal) wall-mounted AC to DC adaptor, through SK1. Reverse polarity protection is provided by the 22 V transient suppressor,

D1, in conjunction with PolySwitch™ PS1. Under reverse polarity conditions, D1 conducts, drawing the available short circuit current until PS1 trips. D1 also protects against any voltage spikes that may come through the AC to DC adaptor. The unit is designed for 10.5 - 14 V operation.

The +5V supply is produced by the regulator, IC1. A feature of this regulator is that it provides a RESET output to the microprocessor. This RESET output is used to delay startup of the microprocessor until the power supply has stabilised after turn-on. It also puts the microprocessor into reset if the input voltage falls too low. D2 sets this low voltage threshold to approximately 9.2 V.

The intelligence of the fast charger is provided by the microprocessor, IC2, which interfaces with the current source, the discharge circuit and the expanded battery voltage interface. The user can interact with the fast charger by pressing the conditioning button, SW1, and can observe the operational state on the tri-colour LED, D5.

The current source is based on a ground-sensing linear topology. R1 and R2 are the current sense resistors. The power device is a P-channel MOSFET, Q4, which is controlled by an operational amplifier, IC3:A. The feedback path that controls the op amp, and hence the current, is through transistor Q5 and its resistor network. The grounding on R23 includes the ground sense resistors in the feedback path. The nominal output current is 800 mA.

Figure E-2: Circuit diagram of the Tait Orca desktop fast charger

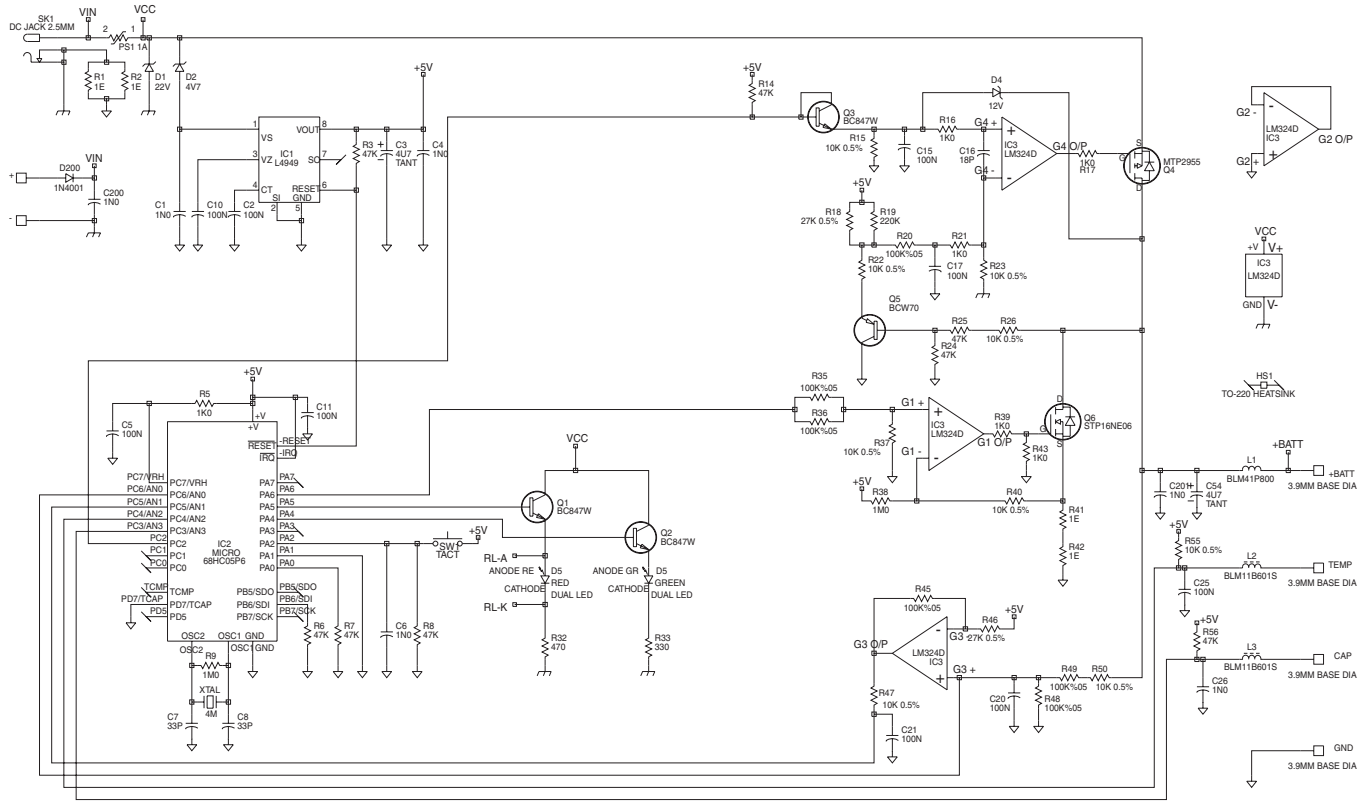

The discharge circuit is based around a constant current sink. This uses an N-channel MOSFET, Q6, controlled by an operational amplifier, IC3:B. R41 and R42 are the current sense resistors that allow the op amp to set the current. The nominal discharge current is 400 mA.

The microprocessor needs to be able to monitor the battery voltage. A coarse voltage is provided by the voltage divider R48, R49 and R50. This voltage divider brings the range of battery voltage into the same range as the microprocessor A/D input (0-5 V). This enables the microprocessor to monitor the general battery voltage. An expanded battery voltage interface is based around operational amplifier IC3:C. It expands a small window of battery voltage over the range of the microprocessor A/D input. This enables the microprocessor to detect small changes in battery voltage and accurately pick when the battery voltage drops below peak.

The interface to the battery is through four contacts, positive (+BATT), temperature (TEMP), capacity (CAP) and ground (GND). The positive and ground contacts are the main connections for charging. In the battery pack, the temperature contact is connected to ground via a thermistor. This allows the charger to monitor the temperature of the battery and if the battery temperature is outside the range +5°C to +40°C, the charger will not charge the battery. The charger also uses the temperature line for detecting the presence of a battery; for example, detecting whether the battery has been inserted or removed from the charger. In the battery pack, the capacity contact is connected to ground via a resistor. If there is a capacitor in parallel with the capacity resistor, then the resulting time constant indicates to the charger that the battery pack is NiMH. Consequently, battery packs that do not have a capacitor in parallel with the capacity resistor are considered to be NiCd.

## Software operation

The charging sequence is as follows.

- Battery discharge (optional);
- Battery flat test;
- Battery type detection;
- Battery open circuit test;
- Battery short circuit test;
- Battery temperature test;
- Rapid charge, with multiple end-of-charge detection methods;
- Rest;
- Trickle charge (optional);
- Standby charge;
- Maintenance charge.

If during trickle or standby charge the battery voltage falls to the discharged battery threshold, the charger restarts the charge cycle as if the battery has just been inserted.



## Using the fast charger

Fast charger indicators are described in Table E-3.

Table E-3: Fast charger indicators

Indicator	Meaning
steady red	battery charging
steady green	battery charged
steady amber	charge suspended until battery temperature is within correct range
flashing red	battery not seated properly in the charger, contacts dirty or battery faulty
flashing green	battery trickle charging
flashing amber	battery being long or short conditioned, or if flashing amber straight away, it may indicate a fault such as dirty contacts

### Charging the battery using the fast charger

Charging using the fast charger involves three stages.

- The fast charge stage quickly brings the battery up to near its full capacity. The charger LED will glow red.
- The trickle stage slowly tops up the battery until it is at its full capacity, which is typically 1½ hours. The charger LED will flash green.
- The standby charge stage keeps the battery at its full capacity, as long as the radio is turned off. The charger LED will glow green.

The battery can be charged separately or attached to the radio. The radio must be turned off to ensure a full charge.

Turn off the radio and insert the battery/radio into the charger. If the indicator does not glow red, make sure the battery/radio is seated properly and the charger is plugged in correctly. If the battery is too hot or too cold, the indicator will remain amber until the battery temperature is within the safe range for

recharging (5°C to 40°C).

Approximate charge times are:

- up to 1½ hours for TOPB100 and TOPB600;
- up to 2 hours for TOPB200, TOPB400 and TOPB700; and
- up to 2½ hours for TOPB500.

Once the battery has reached approximately 90% capacity, the indicator will flash green. At this point, it is recommended the battery be left in the charger for a further 1 to 2 hours, to ensure maximum battery charge. Once the battery is fully charged, the indicator will glow green. Avoid leaving charged batteries in the charger for more than a day.

### Conditioning the battery with the fast charger

Two conditioning functions are available on the fast charger, a short conditioning cycle and a long conditioning cycle. The short cycle discharges the battery then charges it. Regularly recharging a battery that has not been completely discharged will eventually affect its ability to hold a full charge.

For best performance, the battery should be conditioned weekly using the fast charger. Conditioning the battery takes about four to eight hours, depending on how much use it has had.

**Note:** Do not use the short conditioning cycle on a new battery without first fully charging it using a long conditioning cycle.

The long conditioning cycle is necessary:

- before the battery is used for the first time;
- if the battery performance has deteriorated; or
- after the battery has been stored for longer than two weeks.

To short condition the battery

Turn off the radio and insert the battery/radio into the fast charger. When the charger LED glows red, press the conditioning button until the indicator flashes amber. Release the conditioning button. The LED will flash amber while the battery is being discharged. Once the battery is discharged, it will charge normally. The battery is ready to be used again when the charger LED glows green.

To long condition the battery

Long conditioning the battery with the fast charger will put the battery through a number of conditioning cycles and will check the battery's capacity on the last cycle.

To long condition the battery, turn off the radio. Press and hold the conditioning button while inserting the battery/radio. Continue holding the conditioning button until the indicator flashes amber. When the indicator flashes amber, release the conditioning button.

The long condition cycle will take approximately 24 hours.

Once charged, the charger's indicator will glow green if the battery is in good condition. The indicator will flash red if the battery is well below optimum capacity; consult your Tait dealer.

## Repairing the fast charger

The assembly of the fast charger is shown in Figure E-3.

Depress the release tab in the base of the charger using the end of a flat-bladed screwdriver. Holding the lever in, gently pull the body away from the base. Lift out the PCB.

Replace the battery contacts, the tact switch and the DC jack, if necessary.

Figure E-3: Assembly of the desktop fast charger

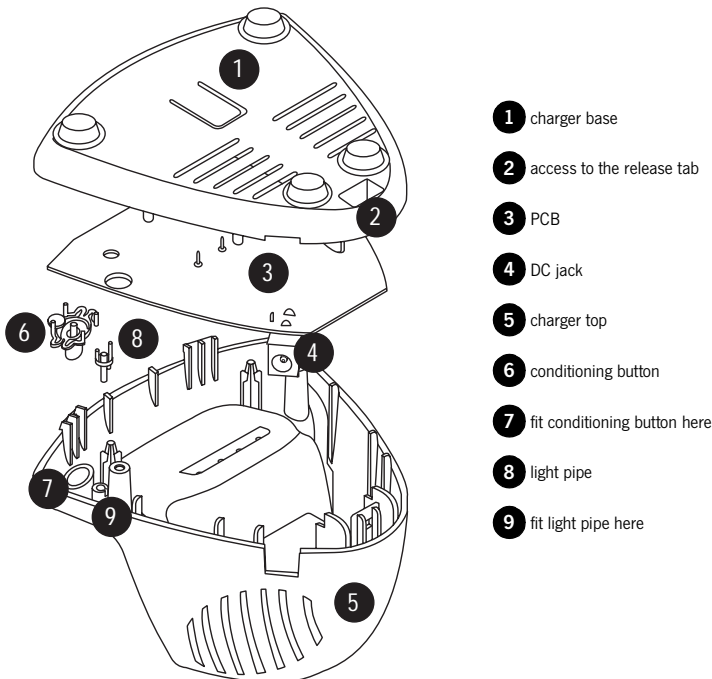

### Replacing the spring contacts

Remove the faulty contacts with a soldering iron and discard.

If the replacement spring contacts have a larger diameter and will not fit through the PCB, the holes should be drilled out to 2.2mm.

When placing the replacement contact, it must not be bent or otherwise damaged. Solder the replacement contact in place using a heavy-tip soldering iron (e.g. Weller 2PTCC8 tip). Hold onto the contact with a pair of pliers and apply solder to the PCB, rather than to the contact, to avoid contact damage.

Figure E-4: The fast charger PCB

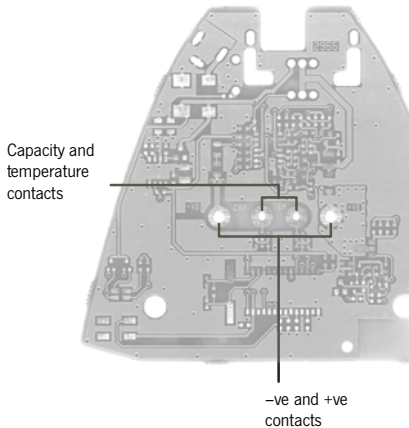

### Reassembling the charger

Refer to Figure E-3.

Hold the body of the charger upside down and insert the conditioning button and the light pipe; both parts self-orient. Place the PCB so it rests on the location pins. Attach the base at the front edge, and clip it down at the back.

Table E-4: Charger Spares and Upgrade Kits:

Product code	Description
TOPA-SP-202	Charger Spares Kit
TOPA-SP-203	Charger Upgrade Kit
TOPA-SP-205	Charger Software Upgrade Kit

### Replacing the discharge tact switch

Remove the tact switch using a desoldering station or solderwick. Place the new part on the board and solder it in place using a medium-tip soldering iron (e.g. Weller PTA7 tip).

### Replacing the DC jack

Remove the DC jack using a desoldering station or solderwick. There is a lot of solder on both sides of the board, so be sure to remove it all.

Place the new part on the board and solder it in place using a heavy-tip soldering iron (e.g. Weller 2PTCC8 tip).

---

# Desktop trickle charger

---

The Tait Orca desktop trickle charger can charge a 1100 mAh or 1500 mAh NiCd battery overnight. It is designed to provide approximately 1450 mAh of charge in a 16 hour period. Thus both 1100 mAh or 1500 mAh NiCd batteries can be charged. Simple protection of the radio is provided in the form of an open circuit voltage limit as well as short circuit protection.

Figure E-5 shows the charger current profile. Figure E-6 shows the circuit diagram for the trickle charger.

## Trickle charger operation

When the battery voltage is above approximately 8 V, the charge current is inversely proportional to the battery voltage. This characteristic is produced by Q100, Q101 and Q102. The charge current is determined by the current through R104, which is set by Q102, its emitter resistors and the reference voltage. The slope of the curve is determined by Q101 and R106. The reference voltage is provided by an 8.2 V Zener diode (D100).

When the battery voltage is below approximately 8 V, the charge current is proportional to the battery voltage. This is accomplished by using Q103 to change the reference voltage in proportion to the battery voltage. This changes the current through R104, which changes the charge current, as desired.

The maximum voltage available from the trickle charger is limited to less than 10.5 V by R111, in conjunction with Q101, so that the radio can not be damaged if the battery goes open circuit. If the battery goes short circuit, then Q102 is held off by Q103 and thus Q100 is off, and there is negligible charge current.

On startup, the state of the charger is similar to that when the charger output is shorted. When power is applied,  $V_{IN}$  starts to rise and the

emitter voltage of Q103 rises. However, the base of Q103 is still at zero volts, so Q103 starts to turn on. When Q103 is on, it will maintain Q102 off and hence Q100 will also stay off. Thus when  $V_{IN}$  has risen to its final value, the circuit is in an off state, giving negligible output voltage and charge current.

In order to activate the circuit, a minimum voltage of approximately 2.6 V (a battery) must be connected to the circuit to charge C101 and turn Q103 off, thus turning on the charger.

The LED is on whenever there is sufficient charge current. Its brightness is proportional to the charge current profile, and its turn-on and turn-off thresholds are determined by R105. Thus the LED is on under normal charging, dims when the battery approaches full charge and is off under fault/no charge conditions.

Figure E-5: Tait Orca desktop trickle charger current charge profile

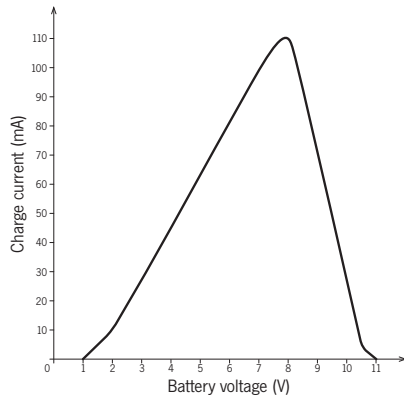
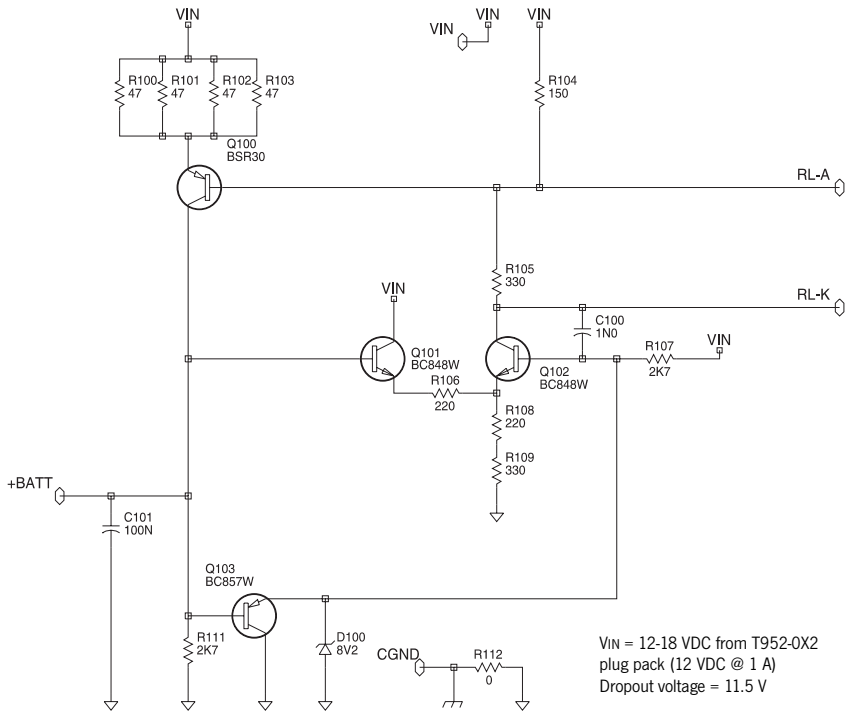

Figure E-6: Circuit diagram of the Tait Orca desktop trickle charger



## Using the trickle charger

The trickle charger is not recommended for NiMH battery packs, as they can take up to 24 hours to charge fully and the overall lifetime of your battery may be reduced. Use a fast charger instead.

The battery can be recharged attached to the radio or as a separate unit. To charge the battery pack using the trickle charger, make sure the radio is turned off. Insert the battery/radio into the charger. Make sure the indicator on the charger glows red. If the indicator does not glow red, check that the battery/radio is seated properly and the charger is plugged in correctly. The indicator will remain red until the radio is removed from the charger.

The battery will be fully charged in about 16 hours. You can leave the battery in the charger

until you next need to use the radio. However, leaving the battery in the charger for longer than 24 hours is not recommended.

## Repairing the trickle charger

For instructions on repairing the trickle charger, refer to those for repairing the desktop fast charger.

## Troubleshooting

*When inserting the battery/radio in the charger, there is no indication on the charger LED.*

- Check that the battery/radio is seated properly in the charger.
- Check that the charger is properly plugged in and the correct plug pack is being used.
- Check that the battery and charger contacts are clean and not obstructed.

Clean the electrical contacts of the battery and charger using a fibre glass pencil, or the graphite tip of a type 4H (#4) or harder pencil.

- May indicate a faulty plug pack or cable. Contact your Tait dealer.

*The charger LED flashes amber as soon as the radio is seated in the charger.*

- Check that the battery and charger contacts are clean and not obstructed.

*The charger LED glows amber.*

- Safe range for charging is 5°C to 40°C, and optimum battery performance will be obtained between 15°C and 25°C. The charger will start charging when the battery temperature is within the range 5°C to 40°C.

*The charger LED flashes red.*

- Check that the battery and charger contacts are clean and not obstructed.
- May indicate a more serious fault such as a faulty battery. Contact your Tait dealer.

*The battery contacts show corrosion.*

- Contact corrosion may start to be noticed later in life, and will reduce battery cell capacity. If early signs of corrosion appear, then clean back and end contacts of the battery using a fibre glass pencil, or the graphite tip of a type 4H (#4) or harder pencil.

---

# Multi-charger

---

The multi-charger (TOPA-CH-300) is made up of six desktop fast chargers that operate independently of one another. Each multi-charger PCB has an additional diode.

## Multi-charger operation

The operation of the multi-charger is the same as that of the desktop fast charger.

Figure E-7: The Tait Orca six-way multi-charger



## Repairing the multi-charger

Should one of the charger units be faulty, you can repair it according to the instructions for the desktop fast charger, or replace the faulty PCB with a fast charger PCB to which the diode (1N4001 or similar) has been added (refer to Figure E-8).

To remove a faulty charger from the multi-charger:

- Unplug the power cord.
- Undo the 10 screws at the base of the radio using a Pozi 1 driver.
- **Do not** pull the top off the charger using the housing of the individual chargers. Instead, from the side of the charger, lift the top cover up and gently fold back.
- Unplug the red and black wires leading to the faulty charger.
- Remove the three screws holding the faulty charger to the top of the multi-charger.
- Gently pull the faulty charger away from the multi-charger top. Turn the charger upside down so that the release tab is at the top.
- Depress the release tab using the end of a flat-bladed screwdriver and gently pull the base away from the body.
- Desolder both wires.
- Repair the board or replace it with a new one to which the required diode has been added.
- Pass the wires through the charger base.
- Solder the red wire to the positive terminal on the PCB and the black wire to the negative terminal on the PCB.
- Place the charger upside down and make sure the conditioning button, the light pipe and the PCB are seated properly.
- Attach the base at the front edge, and clip it down at the back.

- Gently pull the wires through the multi-charger top while aligning the charger with the three screw holes.
- Fasten the charger to the multi-charger top using the three screws.
- Reconnect the red and black wire to the fuse connector. Ensure that the polarity is correct.
- Close up the multi-charger, replacing the 10 screws using a Pozi 1 driver.

Figure E-8: The Tait Orca Fast Charger PCB. The inset shows where to place the diode (1N4001 or similar) for using the PCB in a multi-charger

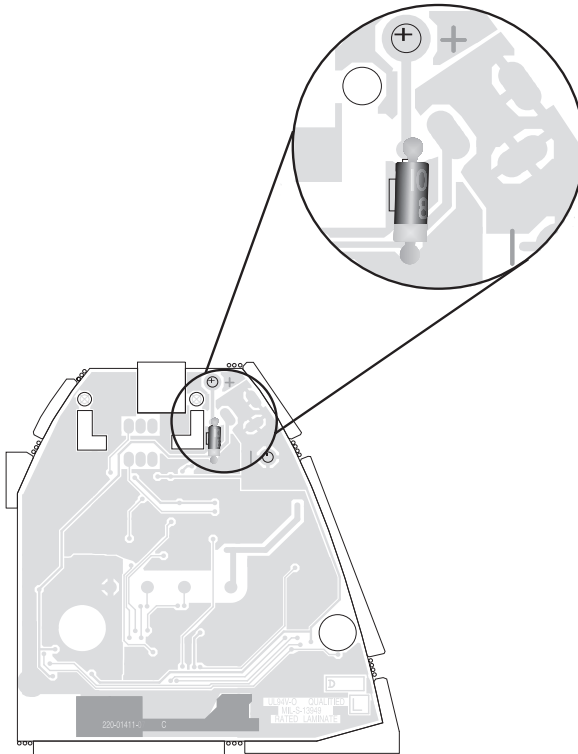

## Fuse replacement

Each charger is protected by a 3A fuse. To replace a fuse, open the multi-charger as described previously. The fuse must be replaced with a 12V 3A secondary fuse made from material with a Class V-2 flammability rating.

A suitable fuse can be ordered directly from

Technical Support, Tait Electronics (IPN 265-00010-64).